

SPJ-4 SQUARE SPLIT FLASHINGS (Vented Cap)

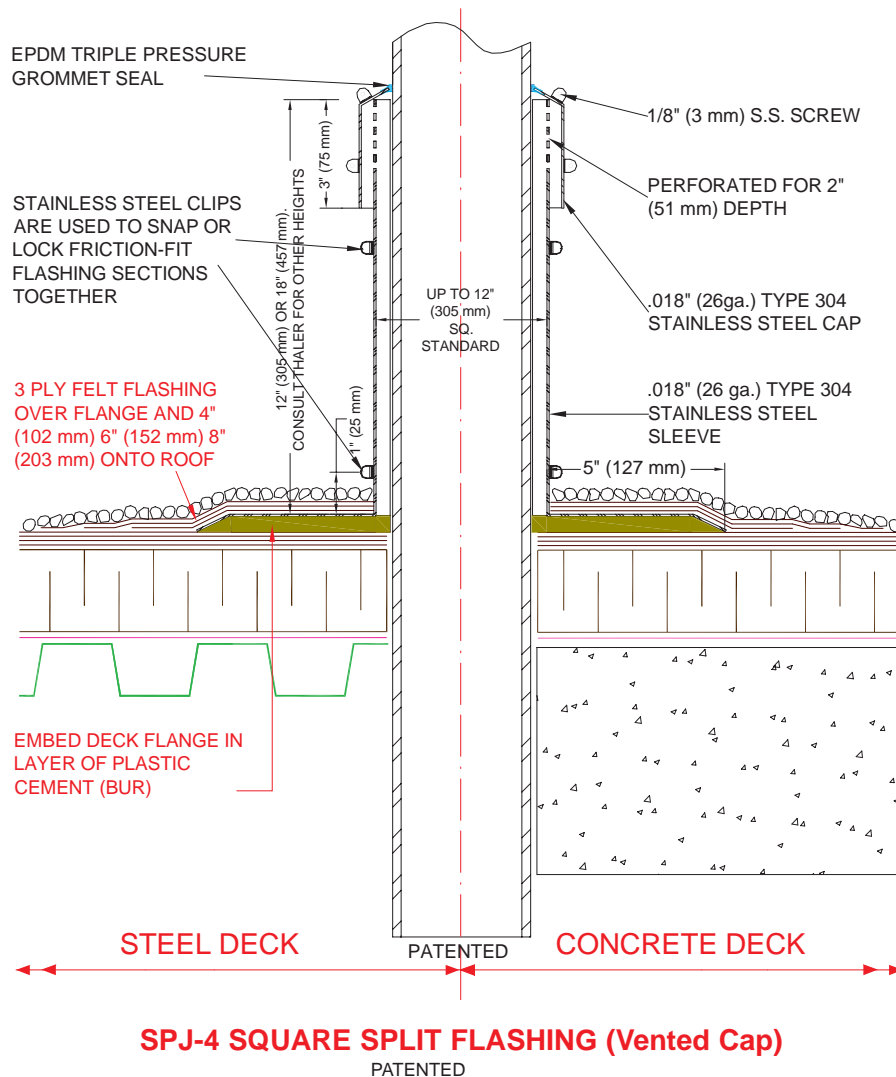
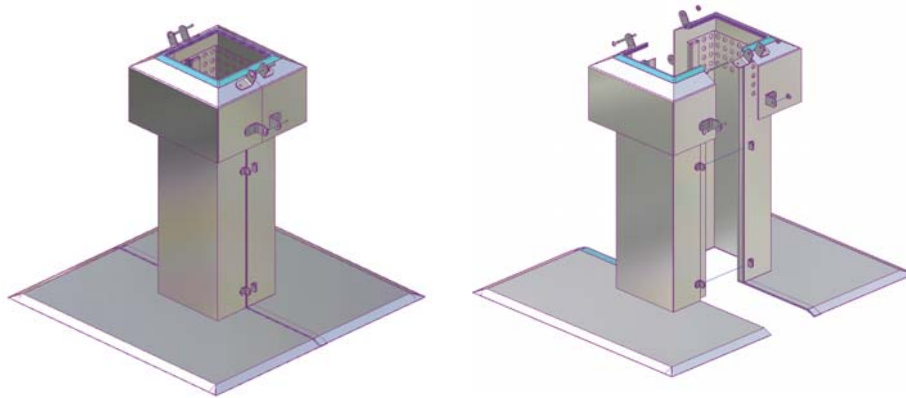

SPJ-4 SQUARE SPLIT FLASHING (Vented Cap)

PATENTED

INSTALLATION

"Installation Instructions" are provided with every Thaler product. Essentially, Thaler split flashings are installed by aligning the two flashing sections, applying silicone lubricant to EPDM seals, snapping the sections together using pliers at clip locations, and as follows:

BUR: Set deck flange in layer of plastic cement and flash in with 3 overlapping layers of felt flashing.

ModBit: Torch membrane until bitumen is fluid and set flange into fluid. Flash in flange with two overlapping layers of ModBit and seal with asphalt sealer.

Single Ply: Set deck flange in layer of membrane adhesive and extend single ply up sleeve as per single ply manufacturer's recommendations and clamp membrane to flashing. Note: for PVC membrane, specify PVC coated flashing by adding suffix P to end of model number, e.g. SJP-4-P; weld roofing to deck flange using PVC torch.

Vented Cap: Fit cap around protrusion and connect the lap joints by re-installing the stainless steel bolts.

Ordering: Available throughout North America. Contact Thaler for lists of distributors and current cost information. Most products readily available from stock.

DESCRIPTION

Thaler SPJ-4 Square Split Flashings consist of a split stainless steel flashing sleeve with integral deck flange and contoured vented cap fitted with an EPDM triple pressure grommet seal. Continuous EPDM seals are also located at the split junctures of the sleeve and deck flange. Available in stainless steel only. Clips are used to snap or lock the friction-fit flashing sections together.

Size: Fits up to 12" (305 mm) square protrusion in any increment.

Height: 12" (305 mm) and 18" (457 mm) is standard. Consult Thaler for other heights.

Prominent Features: Prevents condensation build-up on inside of sleeve. Never needs caulking (see Thaler EPDM Flashing Seals literature).

Options: PVC coated deck flange for PVC roof membrane. Bituminous painted deck flange for BUR and ModBit roof membrane. See SPJ-3 Coolie-Hat Cap for more economical flashing.

RECOMMENDED USE

Suitable for all types of square roof projections where flashing sleeve can only be fitted around the projection rather than over the projection. Example uses include square columns, railings, supports, and other retrofit applications.

APPROVALS

CSA Approved to CSA B272-93 (Prefabricated Self-Sealing Roof Vent Flashings). Note: In addition to the CSA tests, Thaler in-house testing was performed with the EPDM Triple Pressure Grommet Seal submerged in 8" (203 mm) of water for 3 months with no leakage.

WARRANTY

20 year warranty against leaks and defects in materials and/or manufacture when installed in accordance with Thaler "Installation Instructions". Warranty not valid where EPDM seals are subjected to unusually harsh corrosive environments e.g. pulp mills, mining facilities and similar applications.

MAINTENANCE

No maintenance required (maintenance free).

SPECIFICATION (Short Form)

Square split flashings: Thaler SPJ-4 Square, Vented Cap Split Flashing [12" (305 mm) high] [18" (457 mm) high] x [8" (203 mm) square] [of sizes as noted on drawings] .018" (26 ga.) Type 304 stainless steel; to CSA B272-93; with EPDM triple pressure grommet seal around cap and continuous EPDM seals at split junctures of sleeve and deck flange; [PVC coated deck flange] [bituminous painted deck flange]; matching split vented cap with overlapped and s.s. bolted closure design; manufactured by Thaler Metal Industries, 1-800-387-7217 (Mississauga, Ontario, Canada) or 1-800-576-1200 (New Braunfels, TX), installed as per manufacturer's written instructions. Provide 20 year warranty against leaks, condensation and defects in materials and/or manufacture.

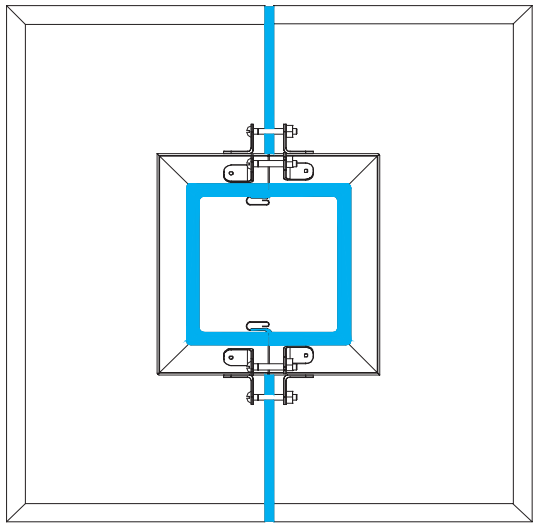

TOP VIEW

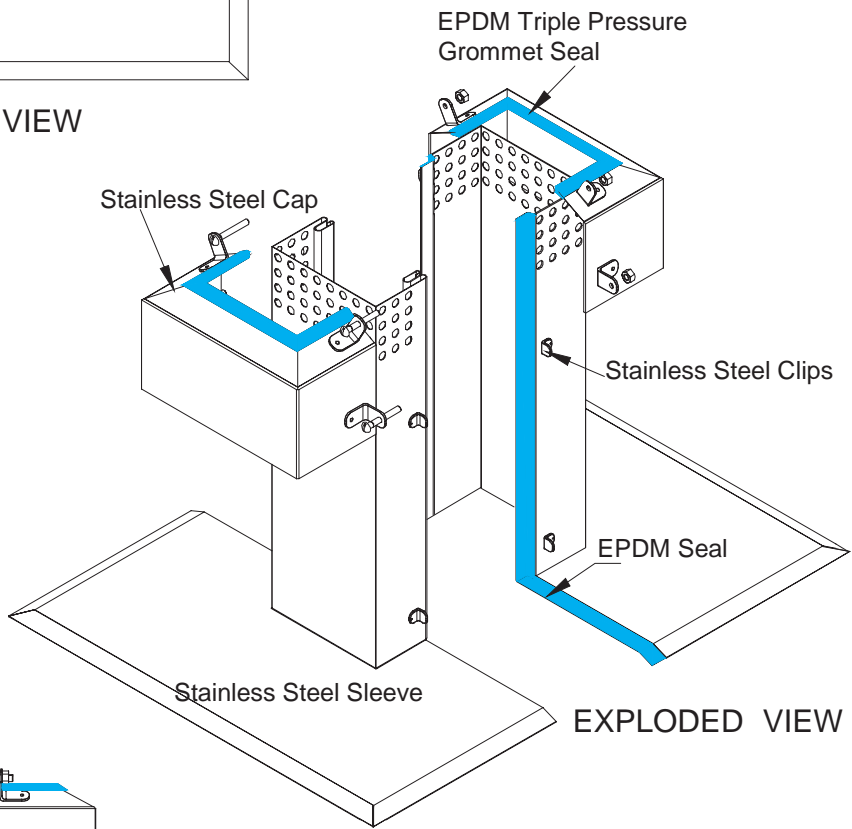

EXPLODED VIEW

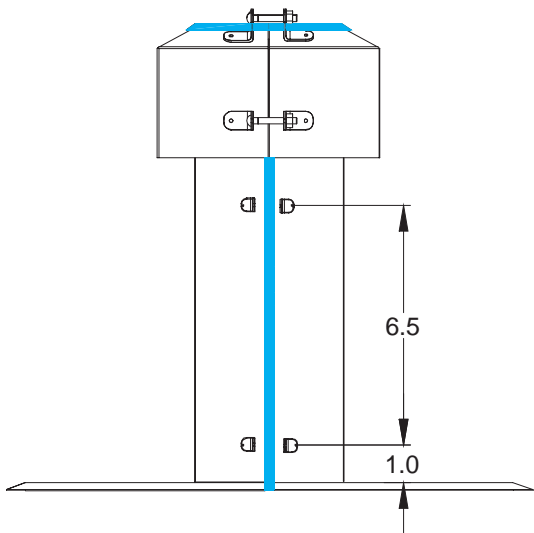

FRONT VIEW