

FORGED EYE (FARA-83/-93)

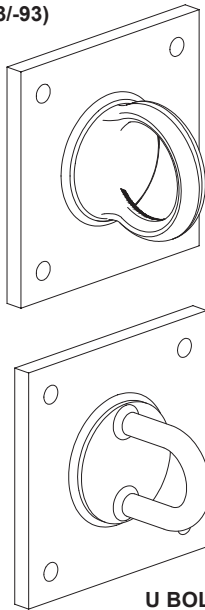

Anchor Type	Eye Construction	Load Direction	Deflection After Load of 5400 lbs (24.03 kN) was Released
FARA-83	Forged Eye, Galvanized	Perpendicular to the eye (x)	0.016" (0.406 mm)
FARA-93	Forged Eye, Stainless Steel	Perpendicular to the eye (x)	0.065" (1.651 mm)
FARA-93U	U Bolt, Stainless Steel	Perpendicular to the eye (x)	0.456" (11.582 mm)

Note: Anchors are designed to resist without fracture and/or pull-out a force of 5400 lbs (24.03 kN), applied in the most adverse direction (x). All testing reports available upon request.

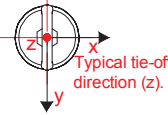

All stainless steel anchor also available (FARA-93SS/-93USS) e.g. eye and base plate.

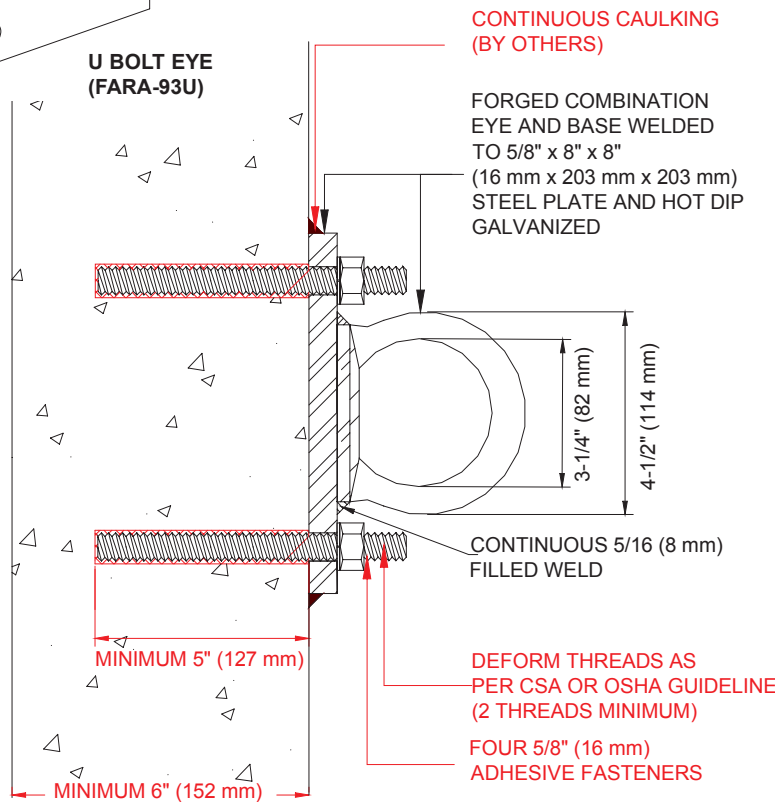

FARA-83/-93/-93U FALL ARREST WALL ANCHORS (Adhesive Bolt)

PATENTED

NOTE: REFER TO PAGES I-34, I-35, I-36 FOR NON-STANDARD HEIGHT ANCHORS

INSTALLATION

"Installation Instructions" are provided with every Thaler product. Essentially, Thaler FARA-83/-93/-93U wall anchors are installed by adhesive bolting (as per bolt manufacturer's instruction) the wall plate to the structural concrete wall as per layout drawings, deforming the exposed threads and applying a caulking bead (by others) around the eye wall plate.

Ordering: Available throughout North America. Contact Thaler for list of distributors and current cost information. Most products are readily available from stock. **Note:** The FARA-93 stainless steel forged eye has a galvanized finish over top of the stainless steel. The process of galvanizing the base plate of the anchor requires the entire anchor to be dipped in the zinc bath, thereby covering the stainless steel eye. If there is any question about a product received on site, the eye material may be checked with a magnet. Type 304 stainless steel is non-magnetic.

**ROOF SPECIALTIES
FARA-83/-93/-93U
FALL ARREST
WALL ANCHORS
(Adhesive Bolt)**

DESCRIPTION

Thaler FARA Adhesive bolt anchors consist of an anchor eye welded to a wall plate which has been prepared to receive adhesive anchor bolts. The anchor eye is available with three different options:

1. With very high strength, *galvanized forged eye* (FARA-83). All stainless steel (FARA-93SS).
2. With very high strength *stainless steel forged eye* (FARA-93). All stainless steel (FARA-93SS).
3. With high strength *stainless steel U Bolt* (FARA-93U). All stainless steel (FARA-93USS).

Prominent Features: Anchor integrity is backed by \$7,000,000.00 liability insurance.

Options: See other Thaler FARA models for different securements.

RECOMMENDED USE

Retrofit product for structurally adequate concrete walls as a fall arrest anchor for securing workers' lifelines or the tying back of suspended access equipment such as out-rigger beams and parapet wall clamps. Also suitable for suspension of boatswain chair.

APPLICABLE STANDARDS

Thaler FARA anchors conform to all Canadian and U.S. standards, provincial and state labour/safety codes and materials standards relating to anchor fabrication, window cleaning and other suspended maintenance operations. Conformance includes CSA, OML, ASME, ANSI, IWCA, OSHA, CAL, OSHA, AISC, AWS, and other references.

WARRANTY

20 year warranty against defects in materials and/or manufacture when installed in accordance with Thaler "Installation Instruction". Copy of Warranty Certificate available upon request.

MAINTENANCE

Regulatory authorities require anchors to be inspected annually with inspection data (date, inspector's name and comments) recorded in the Fall Protection Maintenance Log Book for Window Cleaning and/or Other Suspended Access Maintenance Operations (including travel restraint). Also, the caulking bead around the eye base plate should be inspected periodically and maintained if necessary.

PLANNING SERVICE

Thaler will provide layout drawings for fall arrest anchors in compliance with all applicable standards, safety regulations and local building codes. A nominal, low-cost fee is charged for this service (refunded if Thaler secures the contract to supply the anchors).

SPECIFICATION (Short Form)

Fall arrest wall anchors: Thaler [FARA-83 with galvanized forged 1018 steel eye] [FARA-93 with Type 304 stainless steel forged eye] [FARA-93U with Type 304 stainless steel U bolt] wall anchor to [CSA Z91-02] [OSHA 1910.66, Sub parts D and F] welded to [5/8" x 8" x 8" (16 mm x 203 mm x 203 mm) 44W galvanized base plate] manufactured by Thaler Metal Industries, 1-800-387-7217 (Mississauga, Ontario, Canada) or 1-800-576-1200 (New Braunfels, TX), installed as per manufacturer's written instructions. Provide 20 year warranty against defects in materials and/or manufacture.