

ROOF SPECIALTIES

**TWA-6/-16/-16U
(ECONO) FALL ARREST
ROOF ANCHORS
(Bolt Around OWSJ)**

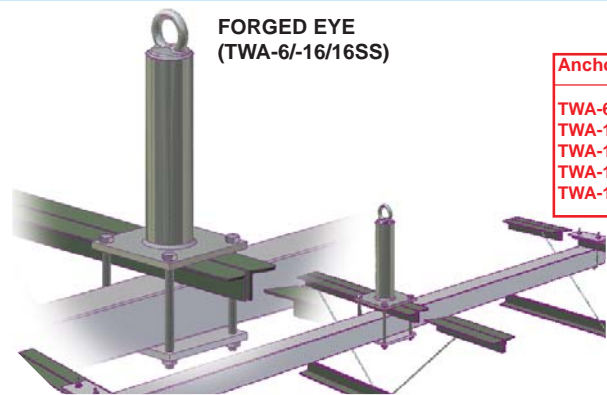

**FORGED EYE
(TWA-6/-16/16SS)**

Anchor Type	Eye Construction
TWA-6	Galvanized Forged Eye
TWA-16	Stainless Steel Forged Eye
TWA-16U	Stainless Steel U Bolt Eye
TWA-16SS	Forged Eye All Stainless Steel
TWA-16USS	U-Bolt Eye All Stainless Steel

Note: Anchors are designed to resist without fracture and/or pull-out a force of 5400 lbs (24.03 kN), applied in the most adverse direction.

**STACK JACK
FLASHING SJ-34 7"
(178 mm) HIGH, SJ-35
13" (330 mm) HIGH**



**U BOLT
EYE
(TWA-16U/-
16USS)**

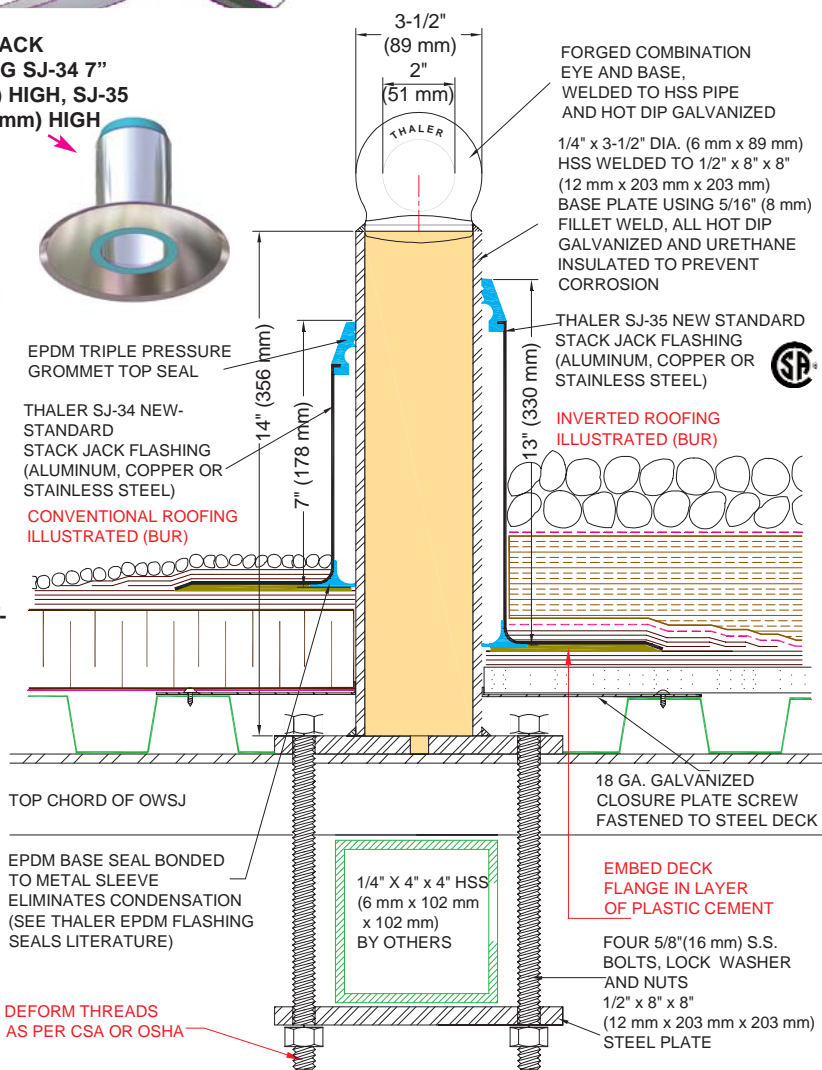

TWA-6/-16/-16U/ (Econo) FALL ARREST ROOF ANCHORS (Bolt Around OWSJ)

NOTE: REFER TO PAGE I-1-8 OF TWA ECONO ANCHORS (I-1 Section) FOR NON-STANDARD HEIGHT ANCHORS

INSTALLATION

"Installation Instructions" are provided with every Thaler product. Essentially, Thaler TWA-6/-16/-16U ECONO Fall Arrest Roof Anchors are installed by bolting the anchor to the top cord of OWSJ as per layout drawings, using a maximum torque of 75 ft-lbf (102 Nm), reinforcing the base plates with cross tube then placing the flashing sleeve over the anchor and roof membrane, and as follows:

BUR: Set flashing deck flange in layer of plastic cement and flash in with 3 overlapping layers of felt flashing.

ModBit: Torch membrane until bitumen is fluid and set flashing flange into fluid. Flash in flange with two overlapping layers of ModBit and seal with asphalt sealer. Do not overheat (melt) EPDM Base Seal.

Single Ply: Set deck flange in layer of membrane adhesive and extend single ply up sleeve to highest elevation possible and clamp membrane to STACK JACK Flashing. Note: for PVC membrane, specify PVC coated STACK JACK by adding suffix P to end of model number e.g. TWA-6-A-P; weld roofing to deck flange using PVC torch.

Precautions: Apply an asphaltic or other type protective coating to aluminum STACK JACK Flashing to a height of 2" (51 mm) above a limestone ballast to avoid corrosive reaction. Also, if coating deck flange with bituminous paint on site, allow 24 hours for drying before applying roof membrane.

Ordering: Specify flashing material required by adding appropriate suffix to model number e.g. TWSLA-6-A, for aluminum, etc. Available throughout North America. Contact Thaler for list of distributors and current cost information. Most products are readily available from stock. **Note:** The TWA-16 stainless steel forged eye has a galvanized finish over top of the stainless steel. The process of galvanizing the lower part of the anchor requires the entire anchor to be dipped in the zinc bath, thereby covering the stainless steel eye. If there is any question about product received on site, the eye material may be checked with a magnet. Type 304 stainless steel is non-magnetic.

DESCRIPTION

Thaler TWA ECONO anchors for OWSJ consist of a urethane insulated hollow steel post (HSS) with base plate, four stainless steel bolts and under-joist plate, and cross tube (supplied by others) for securing to an OWSJ, and flashing sleeve. The top of the anchor is available with three different options:

1. Galvanized forged eye (TWA-6).
All stainless steel (TWSLA-16SS).
2. Stainless steel forged eye (TWA-16).
All stainless steel (TWSLA-16SS).
3. Stainless steel U Bolt eye (TWA-16U).
All stainless steel (TWA-16USS).

Prominent Features: Condensation free and maintenance free (attractive, neat flashing never needs caulking; see Thaler EPDM Flashing Seals literature). Anchor integrity is backed by high \$7,000,000.00 liability insurance.

Options: All stainless steel anchor. PVC coated flashing deck flange for PVC roof membrane. Bituminous painted flashing deck flange for BUR and ModBit roof membrane. See other Thaler TWA ECONO models for different securement.

RECOMMENDED USE

Suitable for all low slope/flat roofs as fall arrest anchors for securing workers' lifelines or the tying back of suspended access equipment such as outrigger beams and parapet wall clamps. Also suitable for suspension of boatswain chair.

APPLICABLE STANDARDS

Thaler TWSLA anchors conform to all Canadian and U.S. standards, provincial and state labour/safety codes and materials standards relating to anchor fabrication, window cleaning and other suspended maintenance operations. Conformance includes CSA, OML, ASME, ANSI, IWCA, OSHA, CAL OSHA, AISC, AWS, and other references. Thaler SJ-34 and SJ-35 New-Standard STACK JACK Flashing conforms to CSA B272-93. See separate Thaler Fall Protection Systems literature for specific data.

WARRANTY

20 year warranty (lifetime on all stainless steel) against leaks, condensation and defects in materials and/or manufacture when installed in accordance with Thaler "Installation Instructions". Copy of Warranty Certificate available upon request.

MAINTENANCE

Regulatory authorities require anchors to be inspected annually with inspection data (date, inspector's name and comments) recorded in the Fall Protection Maintenance Log Book for Window Cleaning and/or Other Suspended Access Maintenance Operations (including travel restraint). Apart from this requirement, Thaler anchors require no maintenance (maintenance free).

PLANNING SERVICE

Without obligation Thaler will provide layout drawings for fall arrest roof anchors in compliance with all applicable standards, safety regulations and local building codes.

SPECIFICATION (Short Form)

Fall arrest roof anchors: Thaler [TWA-6 with galvanized forged 1018 steel eye] [TWA-16 with Type 304 stainless steel forged eye] [TWA-16U with Type 304 stainless steel U bolt] ECONO roof anchor to [CSA 291-02] [OSHA 1910.66, Sub parts D and F] with: urethane insulated, hollow, hot dipped galvanized ASTM 500C steel post (HSS) 1/4" (6 mm) wall thickness x 3-1/2" (89 mm) dia. x 14" (356 mm) high welded to 1/2" x 8" x 8" (12 mm x 203 mm x 203 mm) 44W base plate; 1/2" x 8" x 8" (12 mm x 203 mm x 203 mm) under-joist plate; 1/4" x 4" x 4" (12 mm x 102 mm x 102 mm) cross tube (by others) assembly; four 5/8" (16 mm) Type 304 s.s. bolts; [SJ-34, 7" (178 mm)] [SJ-35, 13" (330 mm)] high New-Standard STACK JACK Flashing of [.064" (1.6 mm) mill finish 1100-01 alloy aluminum] [.032" (0.831 mm) 24 oz. copper] [.031" (0.79 mm) 22 ga. Type 304 stainless steel] to CSA B272-93, with EPDM Triple Pressure Grommet Top Seal and EPDM Base Seal and [bituminous painted deck flange] [PVC coated deck flange]; manufactured by Thaler Metal Industries, 1-800-387-7217 (Mississauga, Ontario, Canada) or 1-800-576-1200 (New Braunfels, TX), installed as per manufacturer's written instructions. Provide 20 year warranty against leaks, condensation and defects in materials and/or manufacture.

THALER 05 11 24 00 MAINTENANCE EQUIPMENT
2005 econo fall arrest roof anchors

